

Grenoble SCD - Friday Ball

1 NEWBURGH JIG J32 · 3/4L

Allana Creighton: RSCDS XLVIII 1 · Crib: SCDDDB Contributed Cribes & Diagrams · Diagram: Keith Rose's Diagrams

- 1- Six hands Round and back.
- 9- Set, cast ; turn LH 1+1/4 to face 1cnr.
- 17- Set to 1cnr, dance R round ptrn to face 2cnr ; set to 2cnr, dance R half round ptrn to end in center facing own side, (1L above/1M below)
- 25- 1L2C/1M3C dance LH Across once round - 1C end on opp. sides ; All set, 1C cross to own sides.

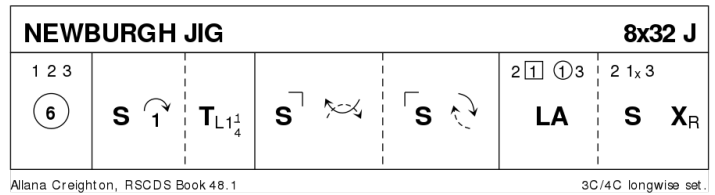

2 RED HOUSE R40 · 2/4L

Playford: RSCDS VII 2 · Crib: E-cribs · Diagram: Keith Rose's Diagrams

- 1- 1c set and cast off one ; set and cast back
- 9- 1M cast off (1W follows) behind 2M, between 2c, behind 2W and cross to finish below 2M/2W
- 17- 1W cast up (1M follows) behind 2W, between 2c, behind 2M and cross to finish 1c in own places
- 25- 1c+2M Reel3 on M sideline (1M & 2M begin Lsh, 1W entering below them ; 1M+2M end in exchanged places, 1W in own place
- 33- 1c+2W Reel3 on W sideline (1W & 2W begin Rsh, 1M entering below them, finish (2,1)

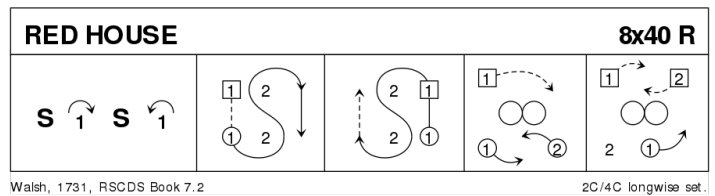

3 ONE SET SHORT OF A HUNDRED S32 · 3/3L

Aliénor Latour: The Paris Book of Scottish Country Dances, vol. 1 · Crib: E-cribs · Diagram: Keith Rose's Diagrams

- 1-- 1c+2c Pousette
- 9-- 1c lead down {3}, up {3} and cast to 2pl (2c up) (2,1,3)
- 17-- 1c+3c Tourbillon
- 25-- Circle6 and back (2,3,1)

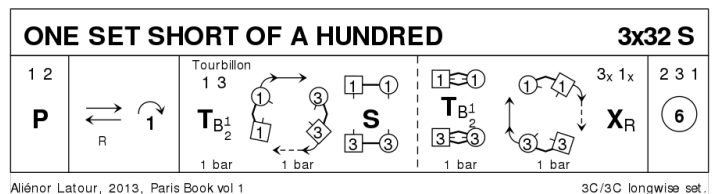

4 TARTAN SHAWL J32 · 3/4L

Martin Sheffield: *Modern Country Dances in the Scottish Tradition, devised since 1970 by Martin Sheffield · Crib: MiniCrib*s

- 1-8 1s 1/2 turn RH, slip step down (as 2s step up) & up to top to end BtoB facing 2nd place opposite sides
- 9-12 1s set in double triangle position, 1s+2nd corners set facing each other diagonally **while** 1st corners change places RH
- 13-16 1s face up/down & set in double triangles, 1s+1st corners set facing each other diagonally **while** 2nd corners change places RH
- 17-24 1s face own sides & set in double triangles position, 1s dance 1/2 reel of 4 with 1st corners & set in double triangles facing up/down
- 25-32 1s dance 1/2 reel of 4 with 2nd corners, 1s turn LH to own sides & set

5 THE COUNTESS OF DUNMORE'S REEL R32 · 3/4L

Deirdre MacCuish Bark: *RSCDS XLIX 12 · Crib: SCDDDB Contributed Crib*s & Diagrams · Diagram: Keith Rose's Diagrams

- 1-- 1c set | dance down (2c up) ; cast up round 3c | set advancing to face 1c nr
- 9-- 1c turn 1cnrs RH, pass Rsh; turn 2cnrs RH, pass Rsh to face out in 2pl (cnrs dance for {4})
- 17-- [3C Chain Progression] 1c cast 1/4 clw round set while{} 2c & 3c Turn RH 3/4 | 2M+3W turn 1 1/2 LH while{} the others promenade 1/2 clw round set | 3c+2c turn RH 3/4 while{} 1c dance clw to 2pl
- 25-- all chase 1/2 way clw ; set - cross RH

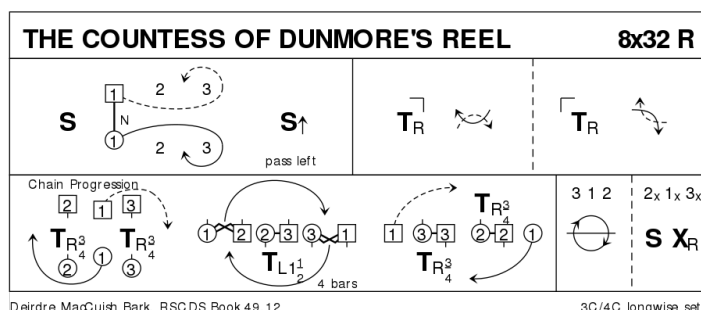

3C Chain Progression was earlier known as Chaperoned Chain Progression

6 THE ROAD TO MALLAIG S32 · 4/4L

Jack Frodsham: *RSCDS XXXVI 2 · Crib: E-cribs · Diagram: Keith Rose's Diagrams*

- 1- 2c+3c RHA ; 1M+2M+3M & 2W+3W+4W 1/2 Reels3 on own sides (1M+2M and 3W+4W begin Lsh)
- 9- 2M+1M+4W+3W (in middle places) LHA ; 2M+1M+4M and 1W+4W+3W 1/2 Reels3 on own sides (1M+4M and 1W+4W begin Rsh) (to order 3,4,1,2)
- 17- 3c+2c chase clw half way round **while** {} 1c+4c half R&L ; 2c+1c & 4c+3c half R&L (to 1,2,3,4)
- 25- All C 1/2 Reels4 on own sides ; 4c+3c+2c 1/2 Reels3 on own side (3c+4c begin Rsh) (2,3,4,1)

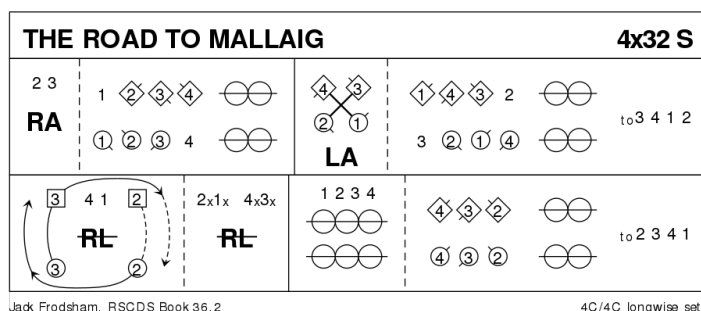

7 THE KISSING BRIDGE R32 · 3/4L

Romaine Butterfield: RSCDS XLVII 9 · Crib: E-cribs · Diagram: Keith Rose's Diagrams

- 1- 1c cast behind own lines and cast back
- 9- 1c cross down into Mirror Reels3 on opposite sides (1x,2,3)
- 17- 1c lead down, cross (M below W, who passes under M's arm) ; and up, 2c steps in for
- 25- 1c+2c Poussette

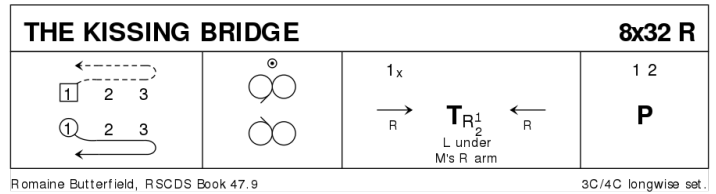

8 MRS STEWART'S JIG J32 · 3/4L

Frans Ligtmans: RSCDS XXXV 1 · Crib: E-cribs · Diagram: Keith Rose's Diagrams

- 1- 1c set | 1W casts, 1M following, round 3W, 1W dances up round 3M and 1M dances up the middle, 1c face 3c (2c up on 7-8) (2,1x,3)
- 9- 2c+1c+3c G-Chain (2c cross), 2M+1M finish facing out
- 17- 2c+1c L-Chain
- 25- 2c+1c+3c A&R ; 1c turn RH 1½ to (2,1,3)

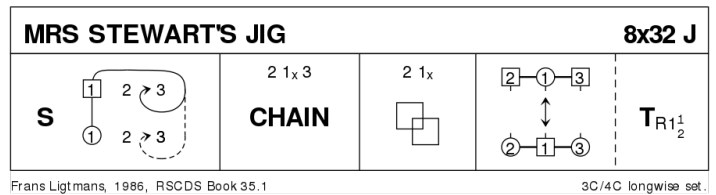

9 INTERVALL

10 GENERAL STUART'S REEL R32 · 3/4L

Castle Menzies (18C): RSCDS X 3 · Crib: E-cribs · Diagram: Keith Rose's Diagrams

- 1- 1M sets to 2W and casts off (2M up) ; 1W sets to 2M and casts off (2W up)
- 9- 1c turn 1cnr RH | pass Rsh ; turn 2cnr LH | pass Rsh to face 1cnr
- 17- SetH&G , finish BtoB facing 1M up / 1W down.
- 25- Reels3{6} with cnrs (Rsh to 2cnr) | 1c cross.

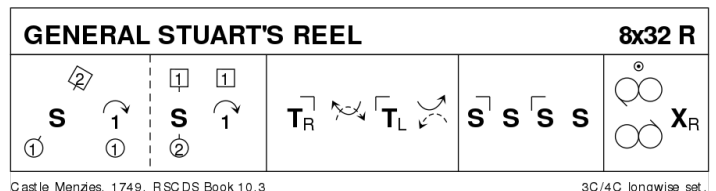

11 GLAYVA J32 · 2/4L

John Drewry: *The Canadian Book of Scottish Country Dances* · Crib: *E-cribs* · Diagram: *Keith Rose's Diagrams*

- 1- 1c+2c ½ DbIFig8 (1c cross down to begin) ; 1c turn 2c easy hand on side (1c inwards) (1x,2x)
- 9- Repeat from new positions (1,2)
- 17- 1c+2c RHA and dance to centre and pull Rsh back ; dance out to places | all set (facing in)
- 25- 1c+2c Espagnole.

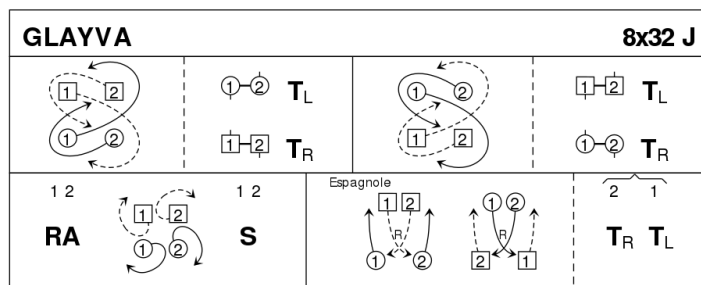

John Drewry, 1976, Canadian Book

2C/4C longwise set.

Espagnole: both W lead RHJ to M side, cross and cast back to exchanged places while {4} Men cross to W side, lead RHJ back to M side and cross to exchanged places ; all turn P EH (2,1)

12 12 COATES CRESCENT S32 · 4/4L

RSCDS: *RSCDS XL 5* · Crib: *E-cribs* · Diagram: *Keith Rose's Diagrams*

- 1- All 4 couples set, cross RH ; repeat
- 9- 1c & 4c dance NHJ to meet in centre, with person opposite dance NHJ out sides, and cast to own places ; 1c lead down to 4pl (2c+3c+4c up on 15-16))
- 17- 3c+4c (middle couples) R&L
- 25- 2c+3c & 4c+1c RHA ; LHA

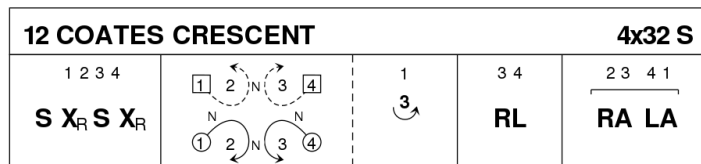

RSCDS, 1998, RSCDS Book 40.5

4C/4C longwise set.

13 THE WALNUT ORCHARD R32 · 3/4L

Anne Dejean · Crib: *E-cribs*

- 1-- 1c dance between 2c and cast up ; dance between 3c and cast up to 2pl (2c up) (2,1,3)
- 9-- Mirror Reels3 on sidelines, joining hands when possible, 1c start in and up, 1c finishing on 1diag RHJ and LHJ with 3cnrs
- 17-- The spoke moving clw (2,1,3)
- 25-- Circle6 and back

14 THE ZOOLOGIST J32 · 3/4L

Duncan Brown: *RSCDS XLVI 12* · Crib: *E-cribs* · Diagram: *Keith Rose's Diagrams*

- 1- 1c cross down RH (2c up) and cast R to between end cpl facing 4cnr ; ½ Lsh Reels3 across, 1c face 1cnr (pos)
- 9- ½ Reel4 on 1diag, 1c pass Rsh and face 2cnr pos. ; ½ Reel4 on 2diag, 1c finish BtoB in middle facing opposite side (3, 1x_mid, 2)
- 17- DTr, 1c finish Rsh to Rsh facing opposite side
- 25- 3c+1M & 1W+2c LHA finish as started ; 1M leading 3c & 1W leading 2c dance to 1cnr {1}, 4cnr {2}, 2pl own side {1}, to finish (2,1,3). This is like the »Snake Pass«, but with sharp angles, forming the letter »Z« for Zoologist (from a note by the deviser).

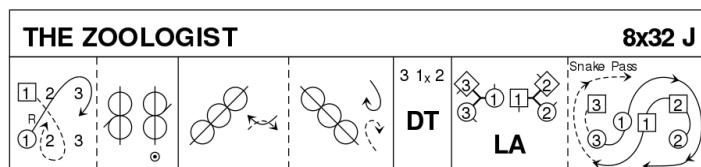

Duncan Brown, RSCDS Book 46.12

3C/4C longwise set.

15 CULLA BAY S32 · 4S

Ann Dix: RSCDS XLI 2 · Crib: E-cribs · Diagram: Keith Rose's Diagrams

- 1-- 1c+3c turn RH ½ with person opposite, face that person | twirl R and into opposite place ; 2c+4c repeat this and face in **while**{4} 1c+3c (W leading) chase ¼ clw | curve into centre and swivel R to face out (1c facing 4pl and 3c facing 2pl)
- 9-- Parallel Reels4 across
- 17-- 2c+1c & 3c+4c circle4 L ; face other couple and set | ½ RHA, flowing into
- 25-- 2c+4c LHA in the middle ; dance out passing same sex standing dancer on the side Rsh, and chase R (M leading) to 1pl/3pl (to 2,3,4,1).

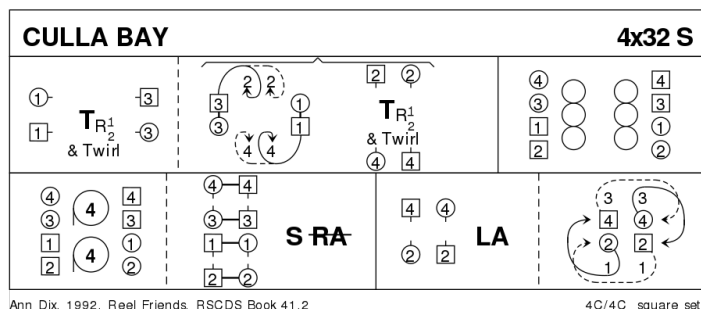

16 LES REMPARTS DE SÉVILLE J32 · 3/4L

Aliénor Latour: RSCDS L 2 · Crib: E-cribs · Diagram: Keith Rose's Diagrams

- 1-- 1c set | cast off (2c up) ; 1c ½Fig8, Lsh to 1cnr
- 9-- 1c turn LH to face 1cnrs | 6 bars of set H&G, into lines across
- 17-- S&Link3 ; all set | all cross RH
- 25-- Circle6 and back (2,1,3)

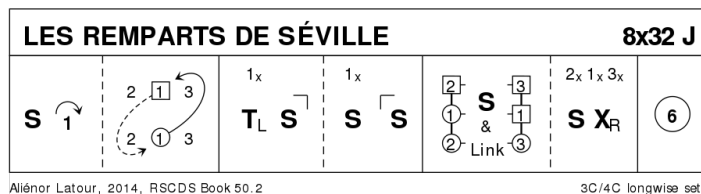

17 THE MONTGOMERIES' RANT R32 · 3/4L

Castle Menzies (18C): RSCDS X 1 · Crib: E-cribs · Diagram: Keith Rose's Diagrams

- 1-- 1c cross RH | cast off (2c up) ; cross LH | cast L (W up, M down)
- 9-- 2c+1W & 1M+3c Rsh Reels3 across
- 17-- 1c NHJ set to 2W (swivel ½ inwards), set to 3M (veer L together), set to 3W (swivel ½ inwards), set to 2M (and face own 2cnr)
- 25-- Reels3{6} on the sides, Rsh to 2cnr | 1c cross RH to 2pl

